



AHRS-8 Attitude Heading Reference System



Description

The AHRS-8 is a fully temperature compensated Attitude Heading Reference System (AHRS), individually calibrated over the -40° to $+70^{\circ}$ C operating range, providing industry leading heading accuracy in a broad range of challenging application environments. The AHRS-8 provides superior performance by eliminating external magnetic disturbances that affect heading accuracy. It provides 3D absolute magnetic field measurement and full 360° tilt-compensated heading, pitch, and roll data. Our AdaptNav II™ adaptive algorithm provides accurate in-field calibration even in the presence of magnetic distortions due to ferrous objects, and noisy environments within the mounting platform. Sparton's NorthTek™ Development System enables the world's only fully programmable navigation sensors, allowing users virtually limitless customizations and applications. The AHRS-8 is fully pin-for-pin compatible with the Sparton DC-4 and GEDC-6 navigation sensors.

Features

- Best in class AdaptNav II™ adaptive algorithm outperforms traditional Kalman filter based approaches by providing real-time optimization of compass performance when used in varying magnetic and dynamic operating environments. AdaptNav II™ also provides revolutionary real-time noise characterizations used for drift compensation of heading, pitch and roll when in electrically and mechanically noisy environments.
- Fully temperature compensated over the entire operating range, individually calibrated from -40° to $+70^{\circ}$ C, providing industry leading heading accuracy in a broad range of application environments
- Powerful user programmable sensor customization apps via NorthTek™ Forth interpreter
- 2D and 3D adaptive in-field cal providing hard and soft magnetic interference compensation
- Advanced sensing technology (3-axis magnetic, 3-axis acceleration, and 3-axis gyro)
- Selectable 4g or 8g accelerometer ranges, suitable for highly dynamic application environments
- Built-in world magnetic model for accurate True North heading anywhere in the world
- Rugged (epoxy encapsulated) construction and small physical size
- Magnetic and True North heading (yaw), pitch, and roll measurement
- Full 360° rollover capability
- Low power consumption and power management (Sleep Mode) functionality
- Supports multiple communication protocols



Specifications

Product specifications are preliminary and are subject to change

Performance data applies to 20° C, 0g Acceleration for Pitch/Roll unless otherwise specified.

Dynamic Heading Accuracy	1.0° RMS ¹
Static Heading Accuracy	0.2° RMS (<1.0° RMS from -40° to +70° C)
Heading Repeatability	0.1° RMS
Dynamic Pitch/Roll Accuracy	1.0° RMS ¹
Static Pitch/Roll Accuracy	0.2° RMS
Pitch/Roll Repeatability	0.1° RMS
Pitch/Roll Range	± 90°, ± 180°
Accelerometer Range (Selectable) ²	+/- 4g or +/- 8g (+/- 1g) ³
Accelerometer Noise Density	126 µg/√Hz
Accelerometer Bias Stability	0.023 mg
Accelerometer Velocity Random Walk (VRW)	0.063 m/s
Gyro Dynamic Range (Selectable)	± 480°/sec (± 300°/sec) ³
Gyro Noise Density	0.03 dps/√Hz
Gyro Bias Stability	10.8°/Hr
Gyro Angular Random Walk (ARW)	1.5 deg/√Hr
Magnetic Range	±1.2 Gauss (±900 MGauss) ³
Maximum Magnetic Inclination (Dip)	± 80°
Update Rate (Samples/Sec)	100
Baud Rate	0.3, 1.2, 2.4, 4.8, 9.6; 19.2; 38.4; 57.6; 115.2 kbaud
Dimensions L x W x H	42 x 28 x 11 mm (1.66 x 1.11 x 0.43 inches)
Mass	16g
Encapsulated or Enclosure	Yes
Operating Temperature	-40° to +85° C
Storage Temperature	-40° to +85° C
Humidity Resistance	95%, 70° C, 240 hrs Meets MIL-STD-202G – Method 103A, Test Condition A
Shock Resistance	1500g, 1ms Pulse, Half-Sine Wave Meets MIL-STD-202G – Method 213B, Test Condition F
Vibration Resistance	.06 dB Power Spectral Density, 9.26 G RMS Meets MIL-STD-202G – Method 214A, Test Condition I/C
Power Supply Input (Unregulated Voltage)	+4 to +10V DC
Input Power, Operating Mode (Typical @ 4V)	330 mW
3.3V Logic UART Interface	Yes
2D and 3D In-Field Calibration	Yes
Able To Maintain Function When Inverted	Yes
Quaternion/Rotation Matrix Output	Yes
True North Heading Output	Yes
NorthTek™ User Programmable Customizations	Yes
Includes World Magnetic Model	Yes
Fully Temperature Compensated	Yes
Individually Calibrated Over Temperature Range (-40° to +70° C)	Yes

¹ *Dynamic heading accuracy derived from Scorsby table set for 7 RPM, 30 degrees of inclination*

² *Note selection of the high range mode for the accelerometers results in decreased sensitivity, but also offers increased dynamic range. Consequently, optimal mode selection is dependent upon the intended application and associated linear accelerations present.*

³ *Specifications in parentheses represent current limits of calibration methodology*

(Specifications subject to change without notice)

Applications

- Weather, data, and ocean surveillance
- Electro-optical target designation sensors
- Accurate vehicle attitude position and orientation sensing
- Ground, sea surface and sub sea surface survey and monitoring
- Precision autonomous vehicle guidance
- Communications antenna pointing and tracking systems
- Challenging application environments requiring high accuracy over a full range of temperature

Connections

Connector – Pin Number	Pin Name	I/O	Function
P1-1	V_TEST	O	3.3V regulator output for test purposes (factory use only)
P1-2	DEBUG_RXD	I	3.3V logic RXD Input to Debug Port (factory use only)
P1-3	DEBUG_TXD	O	3.3V logic TXD Output from Debug Port (factory use only)
P1-4		N/A	Pin removed for keying
P1-5	#WP_EEPROM	I	3.3V logic, active-low EEPROM write protect (the pin has 10kΩ pull-down)
P1-6	Factory Use	I	Do not connect (factory use only)
P1-7	GND	N/A	System Ground
P2-1	V+	I	+4 to +10V DC power supply input. Max load = 80mA
P2-2	USER_RXD	I	3.3V logic RXD input to User Com Port
P2-3	USER_TXD	O	3.3V logic TXD output from User Com Port
P2-4	#RESET	I	3.3V logic, active-low reset input (the pin has a weak pull-up)
P2-5	#EINT0	I	3.3V logic, active-low interrupt input (the pin has a weak pull-up). Used for programming purposes
P2-6	GND	N/A	System Ground
P2-7	GND	N/A	System Ground



sparton
NAVIGATION AND EXPLORATION

Mechanical Data

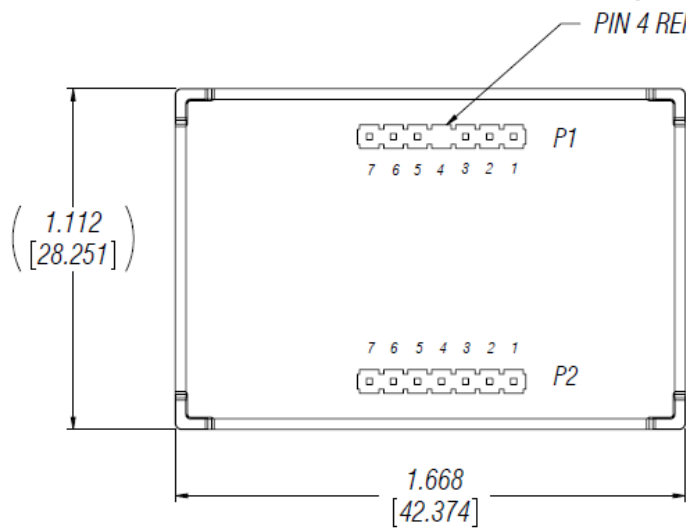
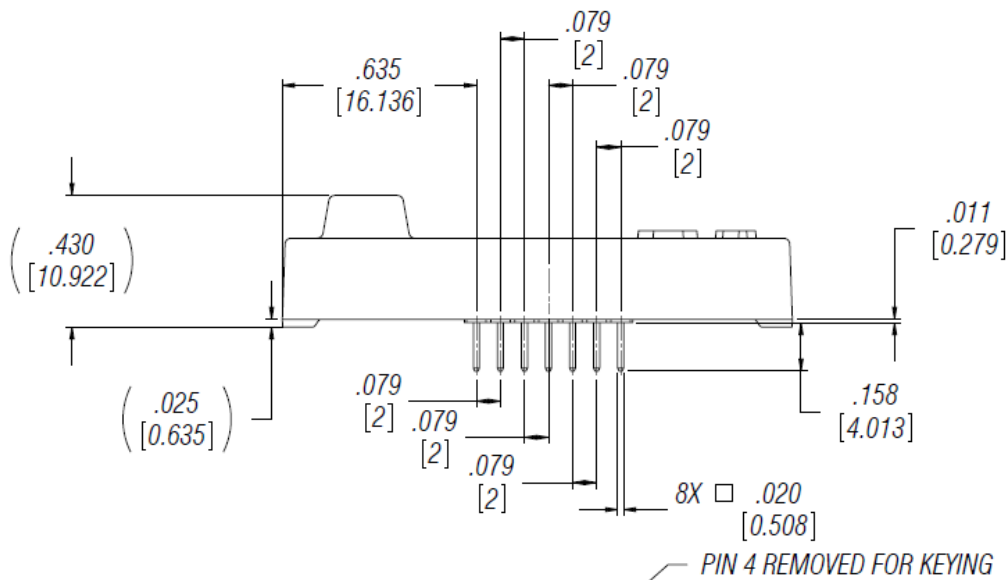
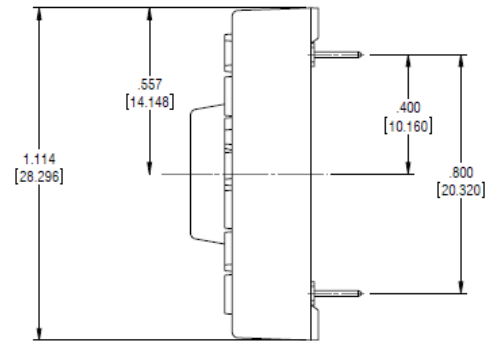
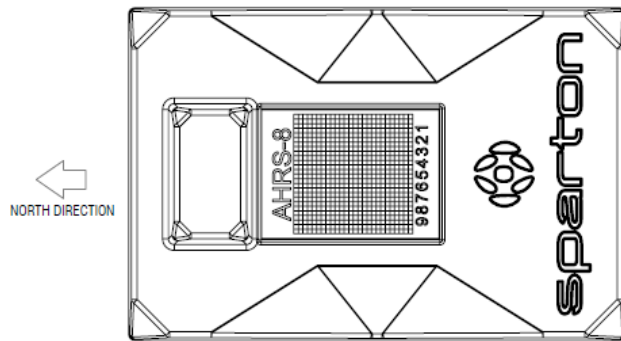

For support, please e-mail productsupport@sparton.com

(Specifications subject to change without notice)